

# Integrated electronic-photonic barrel shifter for high-performance optical computing

Chenghao Feng<sup>1</sup>, Jiaqi Gu<sup>2</sup>, Hanqing Zhu<sup>2</sup>, David Z. Pan<sup>2</sup>, and Ray T. Chen<sup>1\*</sup>

<sup>1</sup>Microelectronics Research Center, The University of Texas at Austin, Austin, Texas 78758, USA

<sup>2</sup>Department of Electrical and Computer Engineering, The University of Texas at Austin, Austin, Texas 78705, USA

\* e-mail address: [chenrt@austin.utexas.edu](mailto:chenrt@austin.utexas.edu)

**Abstract:** We propose a 2-bit electronic-photonic shifter based on microdisk add-drop switches with experimental demonstrations. The proposed shifter can be deployed in future high speed and energy efficient electronic-photonic arithmetic logic units. © 2022 The Author(s)

**OCIS codes:** (200.4660) Optical logic; (250.3750) Optical logic devices; (130.3120) Integrated optics devices

## 1. Introduction

Integrated photonics is a promising technology for high-performance computing thanks to some unique features of light, which are low latency, high bandwidth, and low power consumption<sup>1</sup>. Various photonic circuits are proposed to replace transistor-based logical circuits to implement digital computing and data processing tasks as the continuation of Moore's law has become problematic, e.g., optical adders<sup>2,3</sup>, comparators<sup>4</sup>, decoders<sup>5</sup>, and multiplexers(MUXs)<sup>5</sup>. So far, electronic-photonic circuits can realize most of the building blocks of an arithmetic logic unit (ALU) shown in Fig. 1(a), and they outperform electronic counterparts in both speed and energy efficiency<sup>3</sup>.

The barrel shifter is a combinational logic circuit in microprocessors and is widely used for computing, addressing, and data transportation. However, to our best knowledge, barrel shifters have not been demonstrated in the optical domain. Since a barrel shifter is necessary to realize complicated arithmetic operations such as multiplication and division, a photonic high-speed and energy-efficient barrel shifter is on-demand to construct a fully functional electronic-photonic ALU(EPALU) as depicted in Fig. 1(b).

This paper proposes a novel scheme to realize an N-bit barrel shifter using microdisk add-drop switches as electro-optic (EO) logic gates for high-speed and energy-efficient computation. Combined with other proposed photonic digital computing circuits, a high-speed and energy-efficient electronic-photonic arithmetic logic unit for general-purpose digital computing can be realized.

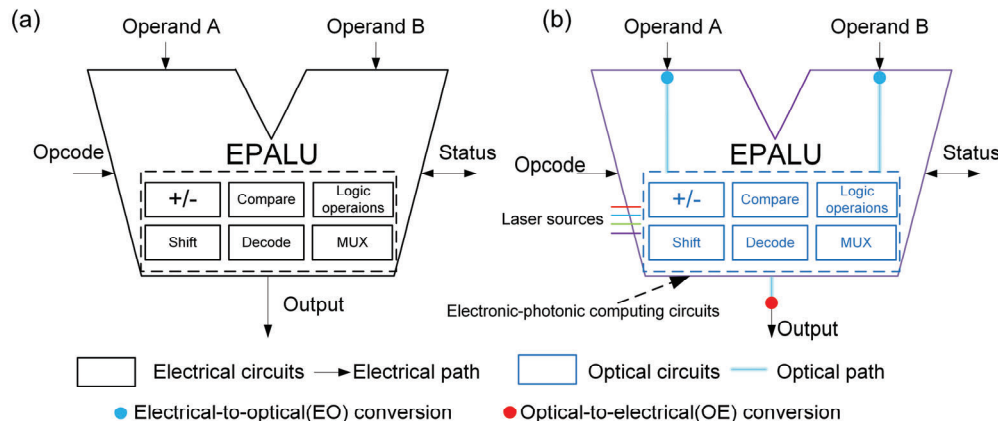

Fig. 1. Schematic of a typical electrical ALU(a) and an electronic-photonic ALU (EPALU) (b). The control circuits and input signals in the EPALU are electrical, but we use electronic photonic combinational logic circuits to replace the electrical counterparts to reduce the total delay and power consumption to implement arithmetic operations. Finally, the optical outputs are converted back to electrical signals for storing or next-stage computation.

## 2. Theory

A barrel shifter shifts an  $N$ -bit data word  $X$  by a specific number of bits  $S$ . The output  $Y$  is shown as follows:

$$Y = X \ll S \text{ or } Y = X \gg S \quad \text{Eq.(1)}$$

where  $\ll$  means left shift and  $\gg$  denotes right shift. Both  $X$  and  $S$  are binary inputs. A barrel shifter can implement multiple shifting functions such as logical shift, arithmetic shift, and rotate with additional processing circuits. The schematic of a 2-bit barrel switch is shown in Fig. 2(a), and sample propagation routes of optical signals under different control signals  $S$ s are illustrated. In an optical barrel shifter, the control signals  $S$  will be applied on the EO switches

simultaneously. These EO switches will direct the propagation paths of optical signals to different output ports. Compared to electrical shifters, the critical path of our electronic-photonic shifter is replaced by an optical route, which is one or two orders of magnitude faster than its electrical counterpart. Using high speed, small footprint, and energy-efficient EO switches<sup>6</sup>, the power consumption of an optical shifter is also about one order of magnitude lower than an electrical shifter, which will be evaluated in detail in the presentation.

### 3. Results

Figure 2(b) shows the micrograph of the 2-bit electronic-photonic barrel shifter fabricated in AIM Photonics. Five add-drop microdisk electro-optical (EO) switches function as EO logic gates, which can direct light to different optical paths according to control signals, as depicted in Fig.2(a). In the testing, the input lights with different wavelengths are generated by a tunable laser. Pseudorandom non-return-to-zero (NRZ) signals are generated by an arbitrary waveform generator and are operated on the thermal pads of the add-drop switches simultaneously. Part of the testing results are shown in Figure 2(a), where we implement  $Y = X \ll S$ , and  $X(x_3x_2x_1x_0) = (0,0,0,1)$ . The clock period in Fig. 2(c) is 1kHz, which is limited by the thermo-optical response time of the switch. It should be noted that the operating speed of our proposed shifter can reach tens of GHz using high-speed carrier-depletion microdisk modulators [5]. We will show more experimental results at higher operating speeds in the presentation.

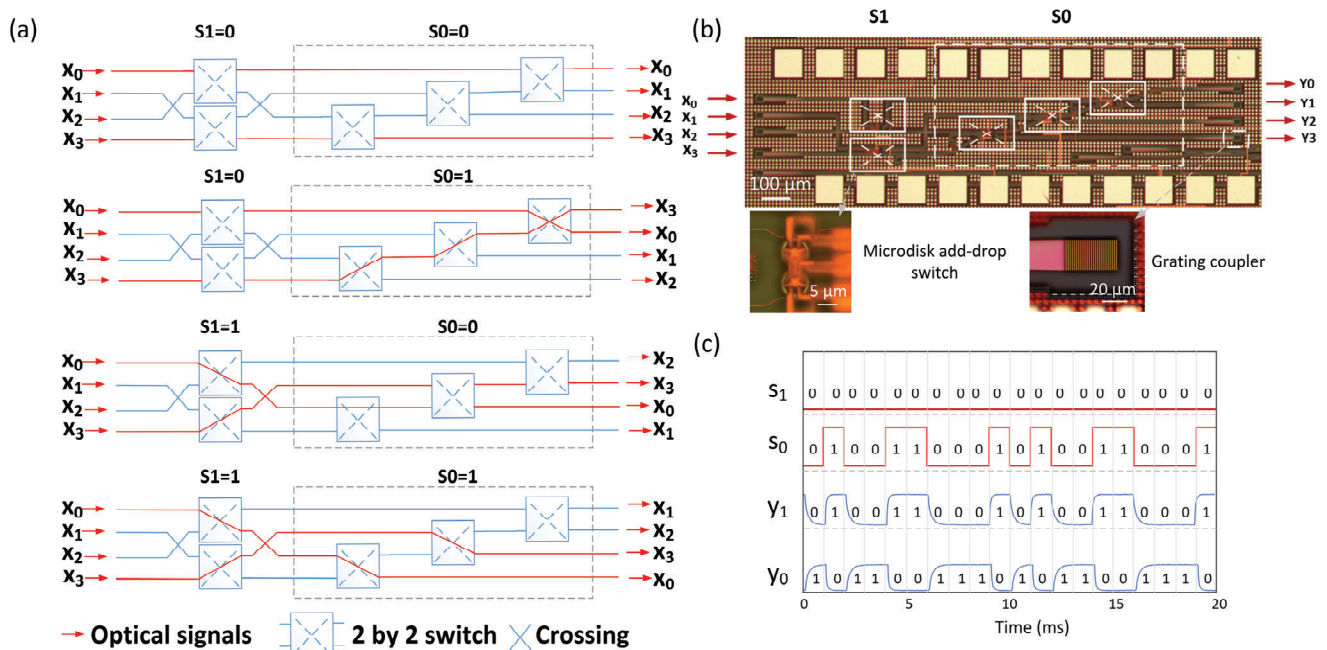

Fig. 2. Schematic of a 2-bit optical barrel shifter. The schematic of the photonic circuit structure is shown in (a). The propagation paths of two optical input signals  $x_0$  and  $x_3$  are shown in red. (b) shows the micrograph of the 2-bit shifter and some optical components. (c) shows a portion of the experimental results, where the optical input  $X(x_3x_2x_1x_0) = (0001)$ ,  $S = (s_1s_0)$ , and the optical output  $Y = (y_3y_2y_1y_0)$ . The testing results match well with our theoretical results.

In conclusion, we have proposed a 2-bit electronic-photonic barrel shifter in experiments using microdisk-based add-drop switches. This design could contribute to future high-performance optical computing with low power consumption and high computational speed.

- Hardy, J. & Shamir, J. Optics inspired logic architecture. *Opt. Express* **15**, 150–165 (2007).
- Gostimirovic, D. & Ye, W. N. Ultracompact CMOS-compatible optical logic using carrier depletion in microdisk resonators. *Sci. Rep.* **7**, 1–10 (2017).
- Ying, Z. *et al.* Electronic-photonic arithmetic logic unit for high-speed computing. *Nat. Commun.* **11**, 2154 (2020).
- Feng, C. *et al.* Toward High-Speed and Energy-Efficient Computing: A WDM-Based Scalable On-Chip Silicon Integrated Optical Comparator. *Laser Photon. Rev.* **15**, 2000275 (2021).
- Feng, C. *et al.* Wavelength-division-multiplexing (WDM)-based integrated electronic-photonic switching network (EPSN) for high-speed data processing and transportation High-speed optical switching network. *Nanophotonics* **9**, 4579–4588 (2020).
- Timurdogan, E. *et al.* An ultralow power athermal silicon modulator. *Nat. Commun.* **5**, 4008 (2014).

The authors acknowledge support from the Multidisciplinary University Research Initiative (MURI) program through the Air Force Office of Scientific Research (AFOSR) (Grant No. FA 955017-1-0071) monitored by Dr. Gernot S. Pomrenke.